



**Operating instructions and
Assembly instructions** (according to directive 2006/42/EC Annex VI)
(ID-No. 00035108)

Stud feeder

HZN-85, HZN-99
ZN-85, ZN-99

00102490	HZN-85	<input type="checkbox"/>	
20010956	HZN-99	<input type="checkbox"/>	assembled:
00102492	ZN-85	<input type="checkbox"/>	Date: _____
20010959	ZN-99	<input type="checkbox"/>	Name: _____

Table of contents

Table of contents	2
1 Preface and general information	3
1.1 General.....	3
1.2 Scope of supply	3
1.3 Intended use.....	3
1.4 Liability	4
1.5 Warranty.....	4
2 Safety information	5
2.1 Personnel responsible for safety	5
2.1.1 Operator.....	5
2.1.2 Qualified personnel.....	5
2.2 General safety instructions	6
2.3 Layout of the safety instructions	6
3 Technical Data	8
3.1 Models.....	8
3.2 Stud types	8
3.3 Dimensions and weight	8
3.4 Noise emission	9
3.5 Ambient conditions	9
4 Commissioning	10
4.1 Installation	10
4.2 Electrical supply (ZN-85, ZN-99)	10
5 Operation of stud feeder	11
5.1 Feeding of studs	11
5.1.1 Feeding by manual operation (HZN-85, HZN-99).....	11
5.1.2 Feeding by electric motor (ZN-85, ZN-99)	11
6 Faults and troubleshooting.....	12
7 Lubrication and maintenance	13
7.1 Lubrication.....	13
7.1.1 Lubricating grease	13
7.1.2 Greasing points.....	13
8 Placing out of service and disassembly	14
9 Spare and wear parts.....	15
9.1 Requirements	15
9.2 Handling of orders	15
9.3 Explanatory notes on of the spare part list	15
9.4 Exploded view HZN-85, HZN-99, ZN-85, ZN-99	16
9.5 Spare part list HZN-85, HZN-99, ZN-85, ZN-99	17
10 Appendix	18
10.1 Declaration of Incorporation	18
10.2 Copyright.....	19
10.3 Manufacturer and contact person.....	19
11 Notes:.....	20

1 Preface and general information

1.1 General

These operating instructions are destined for safe operation of the stud feeders type HZN-85, -99 and ZN-85, -99. The safety instructions included hereinafter have to be observed.

The operating instructions must be available to anybody who is working with the stud feeder and the included instructions must be carefully attended to.

The operating instructions must always be complete and perfectly readable.

1.2 Scope of supply

The delivery normally consists of stud feeder, feeding hose and the operating instructions. The exact scope of supply is specified in the relevant accompanying documents.

These documents must be checked for conformity with the goods immediately after receipt of the delivery. OKU GmbH does not assume any guarantee for defects complained about belatedly.

Therefore,

- contact the forwarder immediately to complain about visible transport damages,
- contact OKU GmbH immediately to complain about visible defects and/or incompleteness of delivery.

1.3 Intended use

The stud feeder may only be used for the feeding of single-flange and multi-flange studs to stud guns and studding machines.

Any other use shall be deemed to be inappropriate!

1.4 Liability

The information, data and notes of these operating instructions were up-to-date when passing for press. The specifications, illustrations and descriptions included hereinafter do not apply to any previously supplied stud feeders.

We do not assume liability for damages and operating troubles caused by:

- inappropriate use,
- unauthorised modifications of the stud feeder,
- improper operation of the stud feeder,
- operating errors,
- disregard of these operating instructions.

1.5 Warranty

Conditions of warranty: see Standard Terms and Conditions of OKU GmbH.

Assert warranty claims against OKU GmbH immediately after detection of the defect or fault.

Warranty claims expire in those cases where liability claims cannot be made either.

2 Safety information

2.1 Personnel responsible for safety

2.1.1 Operator

Operator is called any natural or juridical person who is using the stud feeder or on behalf of whom the stud feeder is used.

The operator and/or his safety officer must ensure that

- all essential regulations, instructions and laws will be observed,
- only qualified personnel will be working with the stud feeder,
- this personnel will have the operating instructions available at any time,
- unqualified personnel will be prohibited from working with the stud feeder.

2.1.2 Qualified personnel

As qualified personnel are to be considered persons who were authorised by the safety officer of the plant to perform the necessary activities and who are able to recognise and avoid potential hazards because of their education, experience, instructions and their knowledge of corresponding standards and rules for the prevention of accidents as well as of the of the operating conditions (see IEC 364, Definition for qualified personnel).

2.2 General safety instructions

These safety instructions do not claim to be exhaustive. In case of any questions please contact OKU.

At the time of delivery the stud feeder is state of the art and regarded as reliable.

The stud feeder is a source of danger for persons, for the stud feeder itself and for other material assets of the operator if

- it is operated by unqualified personnel,
- it is used inappropriately.



Operate the stud feeder only when it is in perfect condition.

Any upgrade, modification or redesign of the stud feeder is basically prohibited. In this case please always confer with OKU.

2.3 Layout of the safety instructions

The safety instructions described hereinafter are arranged consistently.

Warning about personal injury

Pictogram	Meaning	Signal words	Guideline
	Warning about dangerous electrical voltage	Danger!	Warns of imminent danger . Consequences if disregarded: Death or most severe injuries
	Warning about a general danger	Warning!	Warns of a potential very dangerous situation . Consequences if disregarded: Death or most severe injuries
	Warning about a general danger	Caution!	Warns of a potential dangerous situation . Consequences if disregarded: Light or minor injuries

Warning about material damage

Pictogram	Meaning	Signal words	Guideline
	Warning about material damages	Stop!	Warns of potential material damages . Consequences if disregarded: Damage to the stud feeder or its environment.

Other information

Pictogram	Meaning	Signal words	Guideline
	General tip	Tip!	Marks a general useful tip. Adherence thereto will ease the use of the stud feeder.

3 Technical Data

3.1 Models

Model	Id.No.	Notes
HZN-85	00102490	manual operation
HZN-99	20010956	
ZN-85	00102492	driven by electric motor
ZN-99	20010959	

accessory:	00130401	wall holder
------------	----------	-------------

3.2 Stud types

The stud feeder is suitable for feeding of single-flange and multi-flange studs in correct position.

Model		Stud types to be handled
HZN-85	ZN-85	head diameter 8-9 mm, length 10-17,5 mm
HZN-99	ZN-99	head diameter 8 mm, length 10-17,5 mm

3.3 Dimensions and weight

The following values are valid for the stud feeder without any accessories; they may differ according to the respective extra equipment.

Length	approx. 175 mm approx. 272 mm	HZN-85, HZN-99 ZN-85, ZN-99
Width	approx. 196 mm	
Height	approx. 196 mm	
Weight	approx. 1,10 kg approx. 2,45 kg	HZN-85, HZN-99 ZN-85, ZN-99

3.4 Noise emission

The sound pressure level reaches up to 69 dB(A).

3.5 Ambient conditions

Use the stud feeder only in closed dry rooms.

The permissible ambient temperature during operation is from 10 °C to 40 °C.

4 Commissioning

Safety measures to be taken before starting to work with the stud feeder :

- check stud feeder for perfect condition,
- never operate a damaged stud feeder.

4.1 Installation

Place the stud feeder onto the tube on the studding machine or onto the wall holder (accessory) that is fixed to a wall and secure with the screw.

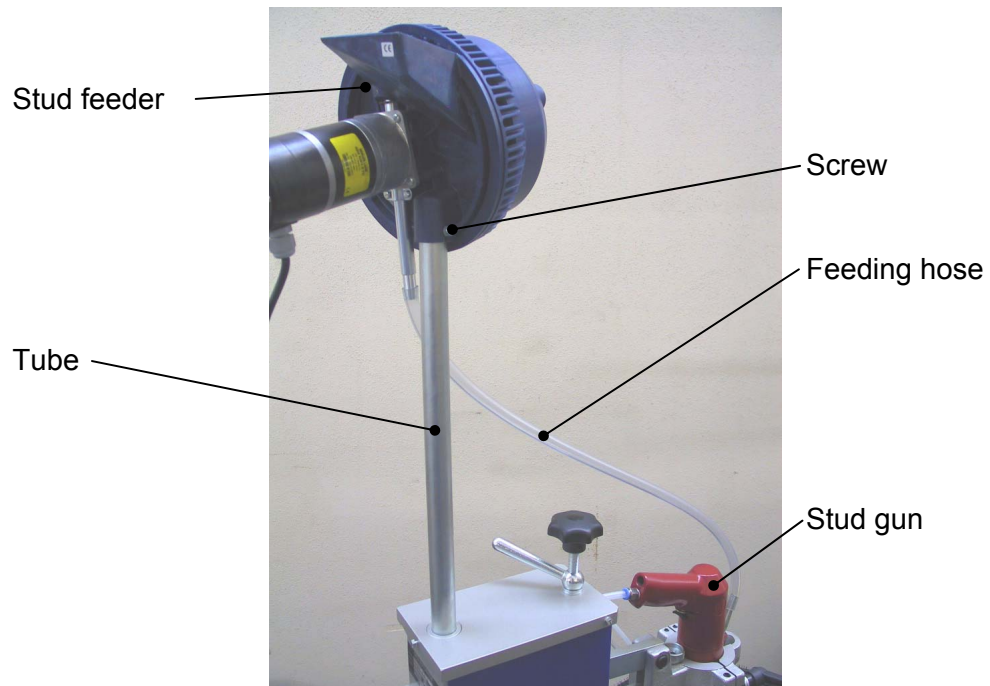

Picture, similar

Connect the stud gun and the stud feeder with the feeding hose. For this purpose cut the hose to length such that it is always in an inclined position.

4.2 Electrical supply (ZN-85, ZN-99)

Connect the power plug of the stud feeder with the power supply system (230 V, 50/60 Hz).

5 Operation of stud feeder

5.1 Feeding of studs

Depending on the model the stud feeder is operated by hand or by an electric motor.

Fill stud feeder with approx. 500 studs. By turning the feed wheel in direction of the arrows the studs are separated and fed in correct position.

5.1.1 Feeding by manual operation (HZN-85, HZN-99)

Turn the feed wheel slowly by hand in direction of the arrows. Thereby the studs are conveyed upwards and fall through the draw spring into the feeding tube. Keep turning the feed wheel until the feeding hose is filled with studs.



Arrows for direction of rotation

5.1.2 Feeding by electric motor (ZN-85, ZN-99)

In automatic mode the stud feeder is permanently driven by the electric motor. If the feeding hose is filled with studs the redundant studs fall back into the feed wheel and they will be fed again.

6 Faults and troubleshooting

Fault	Troubleshooting
Deformed or dirty stud jammed in feeding pipe or feeding hose	Take off feeding hose (18) from feeding tube (12) and remove jammed stud.
No stud dropped into feeding tube	Stud jammed between draw spring (13) and base plate (16). Caution! Models with electric motor: first switch off the motor (17)! Remove jammed stud. Do not damage draw spring.
No stud dropped into feeding tube	Draw spring (13) is damaged Replace draw spring
No stud dropped into feeding tube	Position of draw spring (13) and feeding tube (12) misadjusted Readjust draw spring by setting the position with the grub screws (6) on the feeding tube (see picture below)
Electric motor stops because a stud got jammed between feed wheel and base plate	Models with manual operation: turn the feed wheel (15) slightly backwards until the stud comes off. Models with electric motor : switch off the motor and remove the stud as described before

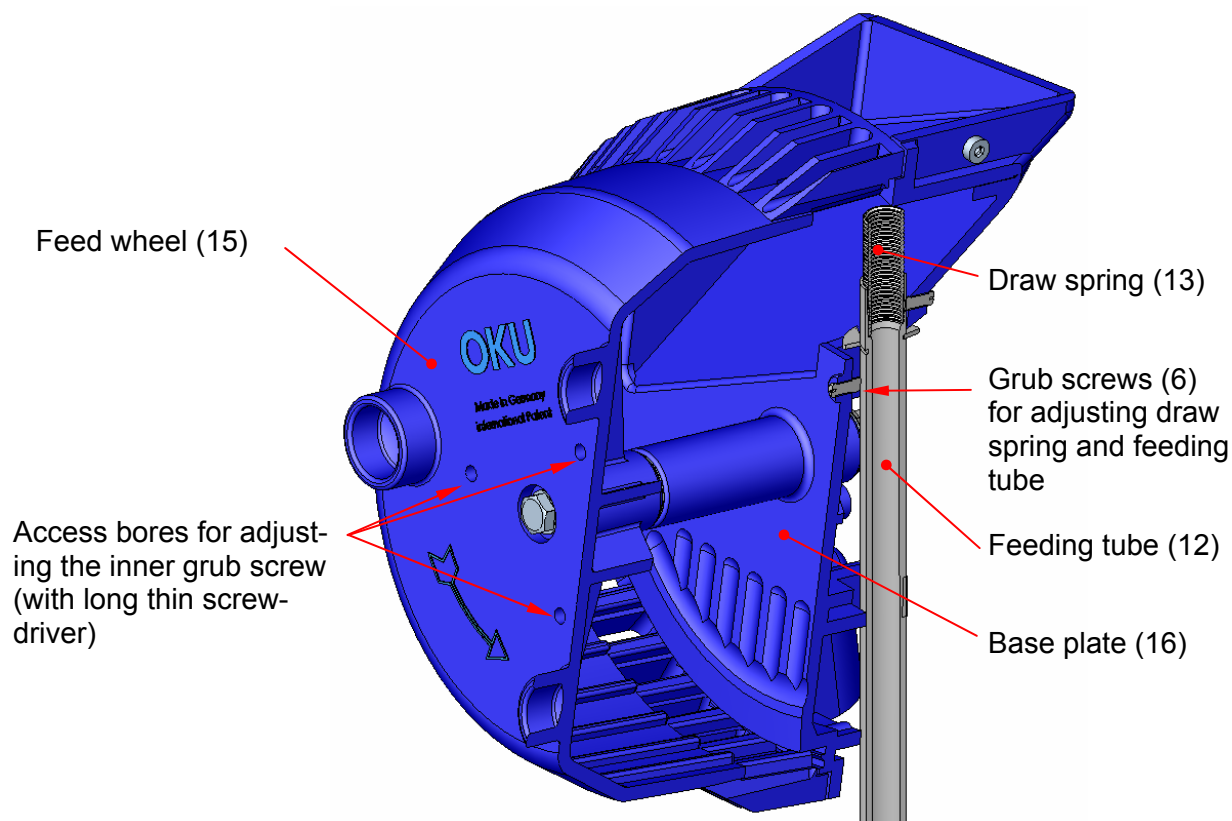

7 Lubrication and maintenance

Clean stud feeder at regular intervals. For the rest the stud feeder is maintenance free.

7.1 Lubrication



Stop!

Follow the effective directions of use and safety for the lubricants applied !

7.1.1 Lubricating grease

Designation acc. to DIN 51825	Description	Consistency Index NLGI Class as per DIN 51818	Worked penetration as per DIN ISO 2137	Manufacturer (manufacturer's designation) e.g.
K2K-20	Lubricating grease for rolling bearings	NLGI-2	265-295	AVIA (AVIALITH 2) BP (Energrease L2) ESSO (Beacon 2) FUCHS (Lagermeister SL) KLÜBER (CENTOPLEX 2 EP) MOBIL (Mobilux 2) SHELL (Alvania R 2)

7.1.2 Greasing points

If during the use of the stud feeder rubbing noises appear between feed wheel (15) and base plate (16), give a minimal quantity of lubricating grease (see 7.1.1) into the gap between feed wheel and base plate.

8 Placing out of service and disassembly

OKU takes back your stud feeder. We recommend you to have OKU professionally disassemble and dispose of the stud feeder.



Tip!

Contribute to environmental protection by recycling valuable raw materials.

What?		Where?
Transport material	Pallets	Return to manufacturer or forwarder
	Packing material	Cardboard boxes to waste paper Plastics to plastic recycling or residual waste Reuse wood wool or to residual waste
Lubricants	Oil, grease	Dispose according to regulations
Components	Materials used: aluminium steel plastics	Dispose of the materials separately

9 Spare and wear parts

9.1 Requirements



Stop!

Spare and wear parts must be in accordance with the technical requirements stipulated by the manufacturer.

9.2 Handling of orders

To ensure punctual handling of orders please always state in your spare part orders the **OKU id.No.** of the required spare part. You will find the **OKU id.No.** in the exploded views and spare parts lists.

9.3 Explanatory notes on of the spare part list

The item number of the required part in the spare part list corresponds to the number of the item in the exploded view.

9.4 Exploded view HZN-85, HZN-99, ZN-85, ZN-99

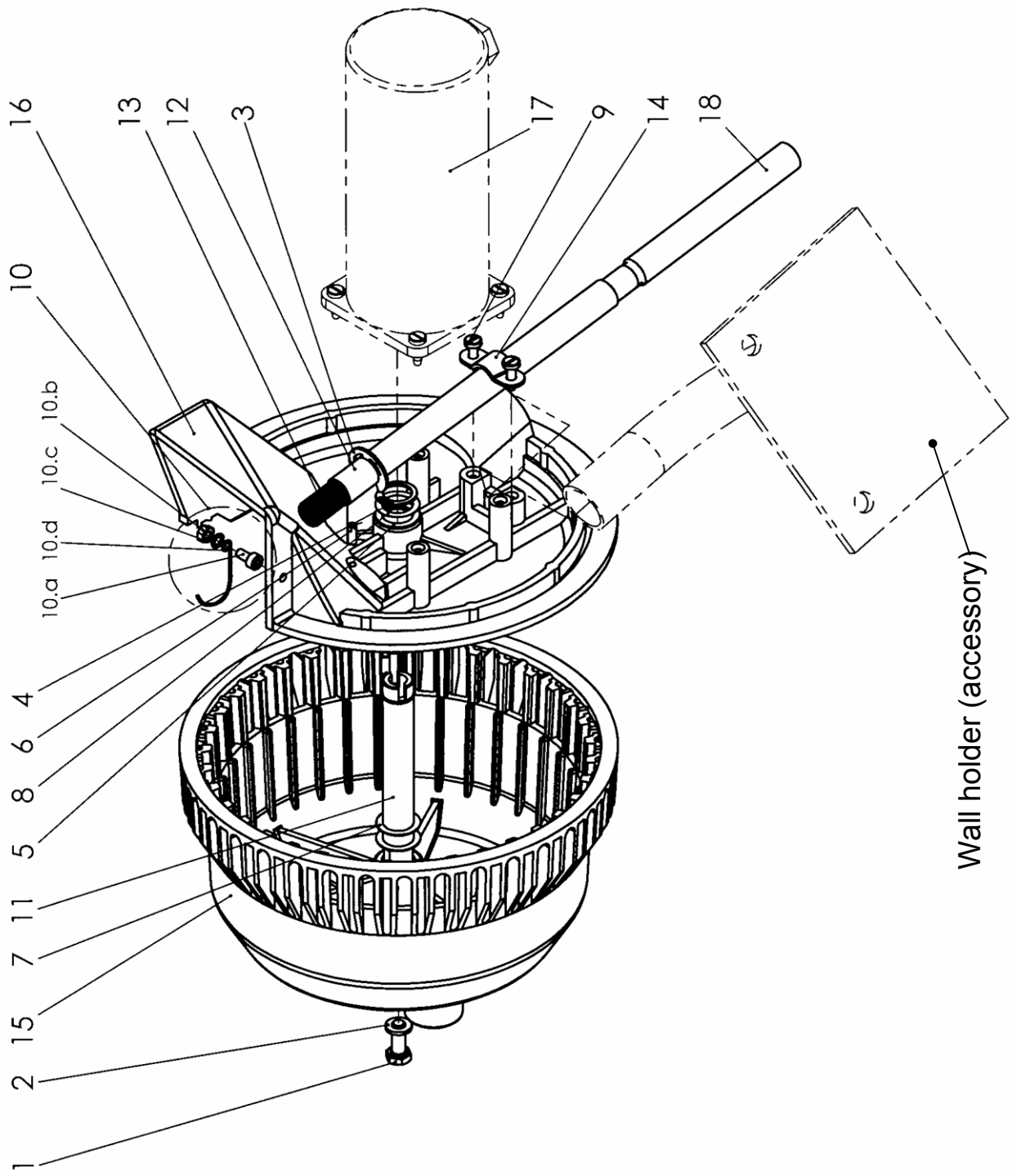

9.5 Spare part list HZN-85, HZN-99, ZN-85, ZN-99

Item	OKU id. No.	Qty	Designation
1	00000119	1	Hexagon screw
2	00000677	1	Washer
3	00000759	1	Retaining washer
4	00000809	1	Circlip
5	00000923	1	Adjusting washer
6	00004610	2	Grub screw
7	00022605	2	Adjusting washer
8	00022610	1	Adjusting washer
9	00025370	2	Self-tapping screw
10	00148773	1	Stud deflecting spring
10 a	00000205	1	Cheese head screw
10 b	00000623	1	Hexagon nut
10 c	00000659	1	Retaining washer
10 d	00422522	1	Spring
11	00350891	1	Shaft
12	00350898	1	Feeding tube 9.3 (HZN-85 and ZN-85)
	00350897	1	Feeding tube 8.3 (HZN-99 and ZN-99)
13	00350904	1	Spring (HZN-85 and ZN-85)
	00350857	1	Spring (HZN-99 and ZN-99)
14	00350918	1	Bracket
15	00650866	1	Feed wheel
16	00650980	1	Base plate
17	00130403	1	Gear motor (for ZN-85 and ZN-99)
18	00004106	1	Feeding hose (for studs head dia. 8 mm)
	00004107	1	Feeding hose (for studs head dia. 9 mm)
	00130401	1	Wall holder (accessory)

10 Appendix

10.1 Declaration of Incorporation

Declaration of Incorporation

for partly completed machinery
(CE Machine Directive 2006/42/EC, Appendix II B)

The manufacturer: OKU GmbH
Assembly and Feeding Systems
Rosenstr. 15
73650 WINTERBACH, GERMANY

OKU

OKU GmbH
Assembly and Feeding Systems
Postfach 11 20
73643 WINTERBACH
GERMANY

Delivery address:
Rosenstraße 15
73650 WINTERBACH
GERMANY

Phone +49 7181 707-0
Fax +49 7181 707-170
E-Mail info@oku.de
Internet http://www.oku.de

herewith declares that the partly completed machinery

designation: **Stud feeder, models: FN-6,5, FN-8, FN-9, FN-10, ZN-85, ZN-99, F-12, F-15**

as delivered complies all relevant regulations of the CE Machine Directive 2006/42/EC, as far as possible within the scope of delivery.

Moreover, the machine complies with all the regulations of the EMC Directive (2004/108/CE).

Harmonized standards applied:

EN 60204-1	Safety of machinery – Electrical equipment of machines – Part 1: General requirements
EN ISO 12100-1/A1	Safety of machinery – Basic concepts, general principles for design – Part 1: Basic terminology, methodology
EN ISO 12100-2/A1	Safety of machinery – Basic concepts, general principles for design – Part 2: Technical principles

The relevant technical documentation is compiled in accordance with part B of Appendix VII.

Upon reasoned request, we undertake to transmit these documents to the market surveillance authorities.

Authorized person to compile the relevant technical documentation:

Armin Layher, Rosenstr. 15, 73650 Winterbach

The partly completed machinery must not be put into service until the final machinery into which it is to be incorporated has been declared in conformity with the provisions of the regulations of the CE Machine Directive 2006/42/EC, where appropriate.

Winterbach, 01/01/2010

OKU GmbH
Assembly and feeding Systems

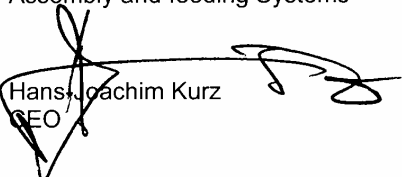
Hans-Joachim Kurz
CEO

Spikes-Zufuehrgeraet-EG-Einbauerklaerung-GB-01-2010



Legal form
Gesellschaft mit beschränkter Haftung, domicile Winterbach
Registration court Stuttgart HRB 280319
CEO Dipl.-Ing. Hans-Joachim Kurz

10.2 Copyright

© 01/2010

This documentation is protected by copyright which covers the exclusive rights to reproduce and distribute the documentation, as well as all translation rights. No material published in this documentation must be reproduced photographically or stored on microfilm, in electronic data bases, video disks, etc. Technical modifications reserved.

10.3 Manufacturer and contact person



OKU GmbH
Assembly and Feeding Systems
Rosenstraße 15
73650 WINTERBACH
GERMANY

Postfach 11 20
73643 WINTERBACH
GERMANY

Phone: +49 7181 707-0
Fax: +49 7181 707-170
Internet: <http://www.oku.de>

Your contact person is:

Sales Department Studs	Phone:	+49 7181 707-0
	Fax:	+49 7181 707-170
	E-Mail:	spikes@oku.de

Representant för OKU i Sverige



Inprotec Automation AB
Flöjelbergsgatan 8B
431 37 Mölndal

Telefon: 031-761 67 00
www.inprotec.se

Kontaktpersoner försäljning och reservdelar

Peter Fellsner
Telefon: 031-761 01 10
Mobil: 0707- 80 28 40

John Carlson
Telefon: 031-761 01 20
Mobil: 0707- 80 28 20